

PennEngineering®

PEMFLEX® SELF-LOCKING,
SELF-CLINCHING FASTENERS

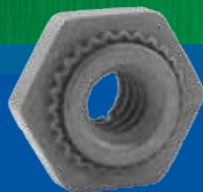

BULLETIN

LK



PEMFLEX® SELF-LOCKING, SELF-CLINCHING FASTENERS

PEM® self-locking, self-clinching fasteners retain their repeated use and effective prevailing locking torque.

- Hex shoulder provides increased pull-thru performance.
- Flexing action of locking feature permits repeated use and effective locking torque.
- Hex shoulder provides positive stop during installation.

The thread locking performance of Types LK, LKA, and LKS PEMHEX self-clinching fasteners (with MD finish) is equivalent to applicable NASM25027 specifications. The self-clinching feature is the same tried and proven design preferred and appreciated for fast, simple assembly. These fasteners do not protrude through one side of the sheet and provide positive, permanent attachment with high torque-out (many times greater than locking torque) and pushout resistances.

PEM all-metal, self-locking fasteners are available in steel, stainless steel, and aluminum. Types LK (steel) and LKS (stainless) are treated with a black dry film lubricant for better locking performance. Type LKA (aluminum) must be used with a lubricated screw. The PEM design utilizes two rugged, semicircular flexing jaws instead of several less-supported segments. The greater ruggedness and retention of this PEMFLEX action prevents relaxation and loosening of the fastener in severe service.

This PEMFLEX design also protects the screw threads. Clearances obtained by only two interruptions of a full circumference, together with the spreading of the jaws by the entering screw, minimize the possibility of thread damage.

PART NUMBER DESIGNATION

LK S - M3 - 1 MD

↓ ↓ ↓ ↓ ↓
Type Fastener Material Code: Thread Size Code Shank Code Finish Code:

None on heat-treated carbon steel nuts.
A on aluminum nuts.
S on 300 series stainless steel nuts.

MD on steel and stainless steel nuts.
No suffix on aluminum nuts.

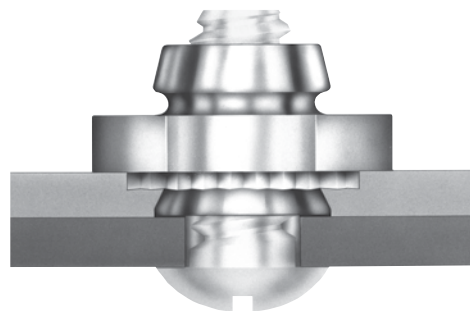

The PEMFLEX semicircular flexing jaws



PEMFLEX® SELF-LOCKING, SELF-CLINCHING FASTENERS

Groove indicates metric part

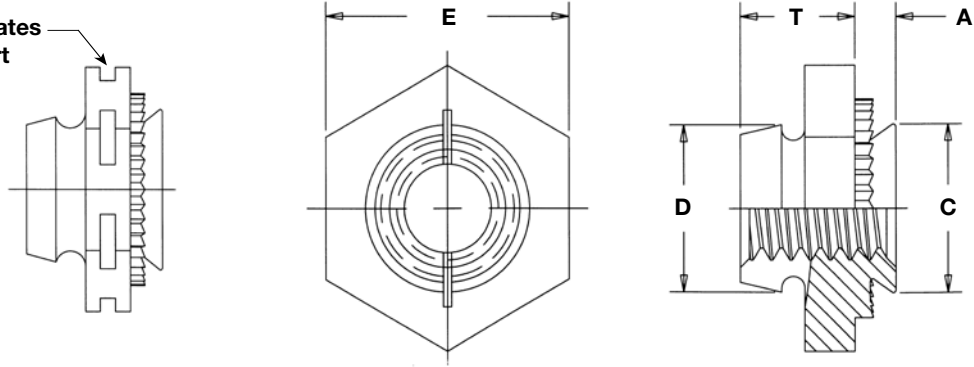

All dimensions are in millimeters.

METRIC	Thread Size x Pitch	Type			Thread Code	Shank Code	A (Shank) Max.	Min. Sheet Thickness	Hole Size In Sheet +0.08	C Max.	D Max.	E Nom.	T ±0.25	Min. Dist. Hole ϕ To Edge
		Fastener Material												
		Carbon Steel	Stainless Steel	Aluminum										
M2.5 X 0.45	LK	LKS	LKA	M2.5	1	0.97	1	4.37	4.35	4.45	6.35	3.43	3.9	
														2
M3 X 0.5	LK	LKS	LKA	M3	1	0.97	1	4.75	4.73	4.85	6.35	3.43	4	
														2
M4 X 0.7	LK	LKS	LKA	M4	1	0.97	1	6.76	6.73	6.2	8.73	4.45	5.2	
														2
M5 X 0.8	LK	LKS	LKA	M5	1	0.97	1	7.92	7.9	7.4	9.53	5.21	5.6	
														2

MATERIAL AND FINISH SPECIFICATIONS

Type	Threads	Fastener Materials			Standard Finishes			For Use In Sheet Hardness (1)	
	Internal, ASME B1.1, 3B/ ASME B1.13M, 6H	Heat-treated Carbon Steel	300 Series Stainless Steel	7075-T6 Aluminum	Black, Dry-film Lubricant Over Zinc Phosphate (2)	Black Dry-film Lubricant (3)	Plain	HRB 70 / HB 125 or Less	HRB 50 / HB 89 or Less
LK	•	•			•			•	
LKS	•		•			•		•	
LKA(4)	•			•			•		•
Part number codes for finishes					MD(5)	MD(5)			

(1) HRB - Hardness Rockwell "B" Scale. HB - Hardness Brinell.

(2) MD finish on steel provides a minimum of 24 hours of salt spray resistance.

(3) MD finish on stainless steel provides a minimum of 100 hours of salt spray resistance.

(4) Aluminum mating screws must be lubricated.

(5) See PEM Technical Support section of our web site (www.pemnet.com) for related standards and specifications.

PEMFLEX® SELF-LOCKING, SELF-CLINCHING FASTENERS

INSTALLATION

1. Prepare properly sized mounting hole in sheet. Do not perform any secondary operations such as deburring.
2. Insert fastener into the anvil hole (preferably the punch side) and place the mounting hole over the shank of fastener as shown in drawing to the right.
3. With punch and anvil surfaces parallel, apply squeezing force until hexagonal shoulder contacts mounting sheet. Examples of installation forces are shown below. The sketch at the right indicates suggested tooling for applying these forces.

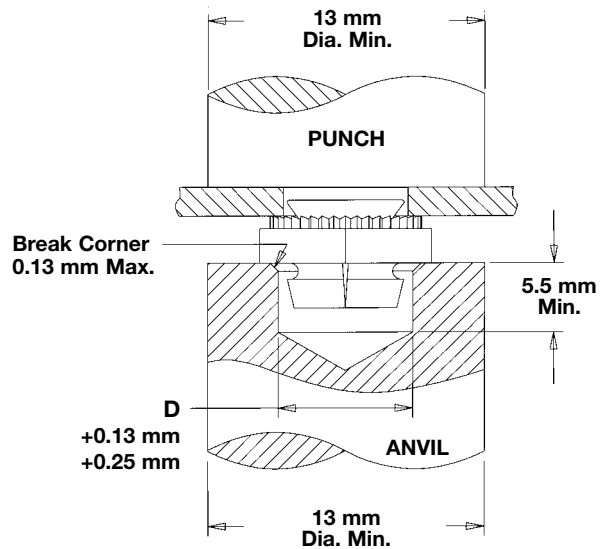

PEMSERTER® PRESSES

For best results we recommend using a PEMSERTER® press for installation of PEM Type LK, LKS and LKA fasteners. Please check our web site for more information.

PERFORMANCE DATA ⁽¹⁾ ⁽²⁾

METRIC	Thread Code	Shank Code	Maximum Prevailing Torque In Locking Element (N•m)	Test Sheet Material					
				5052-H34 Aluminum			Cold-rolled Steel		
				Installation (kN)	Pushout (N)	Torque-out (N•m)	Installation (kN)	Pushout (N)	Torque-out (N•m)
M2.5	1	2	0.45	7.1	578	2.3	13.3	667	2.3
				8.9	667	3.4	13.3	711	2.3
M3	1	2	0.56	7.1	578	2.8	13.3	667	3.4
				8.9	890	4	13.3	1112	4.5
M4	1	2	1.7	12	667	5.1	17.8	845	5.6
				13.3	1112	5.7	19.1	1334	7.9
M5	1	2	2.05	14.2	667	10.2	17.8	1112	11.3
				14.2	1112	11.9	19.1	1334	13.6

(1) The installation, pushout and torque-out values reported are averages when all installation specifications and procedures are followed. Variations in mounting hole size, panel material and installation procedure will affect results. Performance testing of this product in your application is recommended. We will be happy to provide samples for this purpose.

(2) Thread locking performance is equivalent to applicable NASM25027 specifications. Consult document PEM-REF25027 for details.

RoHS compliance information can be found on our website.
© 2011 PennEngineering.

Specifications subject to change without notice.
Check our website for the most current version of this bulletin.

PennEngineering®



North America: Danboro, PA USA • E-mail: info@pemnet.com • Tel: +1-215-766-8853 • Fax: +1-215-766-0143 • 800-237-4736 (USA Only)
Europe: Galway, Ireland • E-mail: europe@pemnet.com • Tel: +353-91-751714 • Fax: +353-91-753541
Asia/Pacific: Singapore • E-mail: singapore@pemnet.com • Tel: +65-6-745-0660 • Fax: +65-6-745-2400
Shanghai, China • E-mail: china@pemnet.com • Tel: +86-21-5868-3688 • Fax: +86-21-5868-3988

Visit our PEMNET™ Resource Center at www.pemnet.com

Technical support e-mail: techsupport@pemnet.com