

PEM® Type MPP™ Self-clinching Micro Pins

PEM Type MPP, self-clinching micro pins are ideal for today's compact electronic assemblies. Simply pressed into a properly sized mounting hole, these micro pins clinch permanently into place. They can be installed into a variety of sheet materials up to HRB 92 / HB 195 in hardness and they offer excellent corrosion resistance.

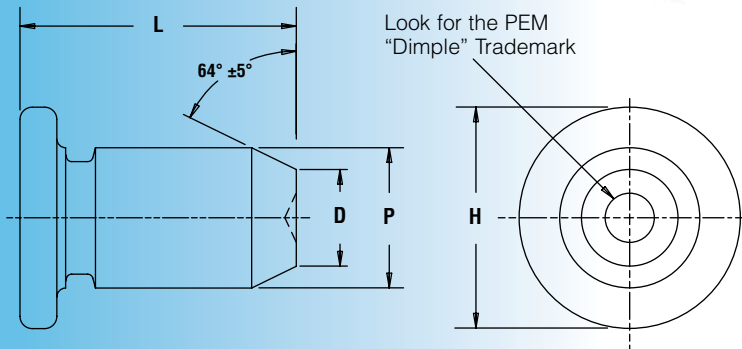

- Features and Benefits**
- Satisfy demanding micro positioning and alignment applications.
 - Head mounts flush into panels as thin as 0.5mm.
 - Chamfered end makes mating hole alignment easy.
 - Can be installed into stainless steel sheets.
 - Excellent corrosion resistance.
 - Can be installed automatically.
 - RoHS compliant.



All dimensions are in millimeters.

Pin Diameter P ±0.038	Type	Pin Diameter Code	Length Code "L" ± 0.15 (Length Code in millimeters)							Min. Sheet Thickness	Hole Size in Sheet +0.025	D ±0.1	H ±0.25	Min. Distance Hole \varnothing to Edge
	Stainless Steel		2	3	4	5	6	8	10					
1	MPP	1mm	2	3	4	5	NA	NA	NA	0.5	1.05	0.7	1.6	2.05
1.5	MPP	1.5mm	NA	3	4	5	6	8	NA	0.5	1.55	1.03	2.24	2.6
2	MPP	2mm	NA	NA	4	5	6	8	10	0.5	2.05	1.36	3.02	4.4

NA Not Available.

Material & Finish Specifications

Fastener Material: Age hardened A286 stainless steel
Finish: Passivated and/or tested per ASTM A380
For Use In Sheet Hardness: HRB 92 / HB 195 or less ⁽²⁾

(2) HRB - Hardness Rockwell "B" Scale. HB - Hardness Brinell.

PART NUMBER DESIGNATION

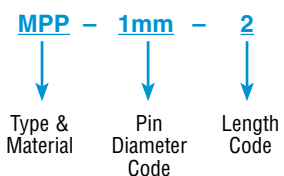

PEM® Type MPP™ Self-clinching Micro Pins

Performance Data⁽¹⁾

Pin Diameter Code	Test Sheet Thickness	Installation (kN)	Pushout (N)
1mm	0.51mm stainless steel HRB 88	10	320
1.5mm	0.51mm stainless steel HRB 88	12	760
2mm	0.51mm stainless steel HRB 88	18	860

(1) The values reported are averages when all installation specifications and procedures are followed. Variations in mounting hole size, sheet material, and installation procedure will affect this data. Performance testing of this product in your application is recommended. We will be happy to provide samples for this purpose or perform the installation for you.

Installation

- 1) Prepare properly sized mounting hole in sheet. Do not perform any secondary operations such as deburring.
- 2) Insert pin through mounting hole (punch side) of sheet and into anvil hole.
- 3) With punch and anvil surfaces parallel, apply squeezing force to embed the pin's head flush in the sheet.

All dimensions are in millimeters.

Type	Pin Diameter Code	Anvil Dimensions
		C ±0.02
MPP	1mm	1.07
MPP	1.5mm	1.57
MPP	2mm	2.07

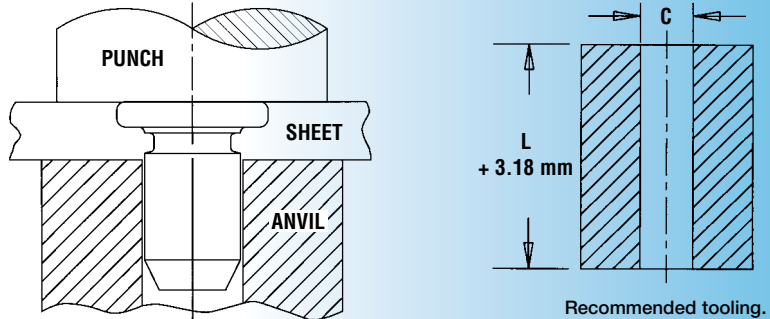

Requirements for Installation into Stainless Steel

1. Sheet hardness must be less than the specified limit for the fastener.
2. Panel material should be in the annealed condition.
3. Fastener should be installed in punch side of hole.
4. Hole punch should be kept sharp to minimize work hardening around hole.
5. Maintain the punch diameter to no greater than +.001"/.025mm over the minimum recommended mounting hole.
6. Fastener should not be installed adjacent to bends or other highly cold-worked areas.

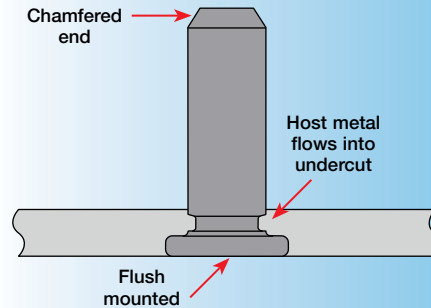

To be sure that you are getting genuine PEM® brand self-clinching pins, look for the "dimple" trademark. (Reg. Pat. & T.M. Off. of the U.S. and other countries.)



RoHS compliance information can be found on our website.
© 2010 PennEngineering.

Specifications subject to change without notice.
Check our website for the most current version of this bulletin.

PennEngineering®



MPP-2

North America: Danboro, PA USA • E-mail: info@pemnet.com • Tel: +1-215-766-8853 • Fax: +1-215-766-0143 • 800-237-4736 (USA Only)
Europe: Galway, Ireland • E-mail: europe@pemnet.com • Tel: +353-91-751714 • Fax: +353-91-753541
Asia/Pacific: Singapore • E-mail: singapore@pemnet.com • Tel: +65-6-745-0660 • Fax: +65-6-745-2400
 Shanghai, China • E-mail: china@pemnet.com • Tel: +86-21-5868-3688 • Fax: +86-21-5868-3988

Visit our PEMNET™ Resource Center at www.pemnet.com