



AE 60 OPERATING INSTRUCTIONS



PennEngineering®



North America: Danboro, PA USA • E-mail: atlas@pemnet.com • Tel: +1-215-766-5987 • Fax: +1-215-766-5988 • 877-682-2505 (USA Only)
Europe: Galway, Ireland • E-mail: europe@pemnet.com • Tel: +353-91-751714 • Fax: +353-91-753541
Asia/Pacific: Singapore • E-mail: singapore@pemnet.com • Tel: +65-6-745-0660 • Fax: +65-6-745-2400
Shanghai, China • E-mail: china@pemnet.com • Tel: +86-21-5868-3688 • Fax: +86-21-5868-3988

Visit our PEMNET™ Resource Center at www.pemnet.com

- Read the instructions carefully before using the tool.
- For all maintenance and/or repairs please contact PennEngineering and use only original spare parts. PennEngineering may not be held liable for damages from defective parts caused by failure to use original spare parts.
- The tool must be used only by expert workers.
- A protective visor and gloves must be put on when using the tool.
- Use equipment recommended in the maintenance chapter to do any maintenance and/or regulation of the tool.
- For topping off the oil, we suggest using only fluids in accordance with the features specified in this working book.
- If any drop of oil touches your skin, you must wash with water and alkaline soap.
- The tool can be carried and we suggest putting it into its box after using.
- The tool needs a thorough six-monthly overhaul.
- Repairing and cleaning operations must be done when the tool is not fed.
- If it is possible, we suggest a safety balancer.
- If the A-weighted emission sound pressure level is more than 70 dB (A), you must use some hearing protections (anti-noise headset, etc.).
- The workbench and the work surface must be always clean and tidy to avoid injury.
- Do not allow unauthorized persons to use the working tools.
- Make you sure that the compressed air feeding hoses have the correct size to be used.
- Do not carry the connected tool by pulling the hose. The hole must be far from any heating sources or from cutting parts.
- Keep the tools in good conditions; do not remove either safety parts or silencers.
- After repairing and/or adjusting, make sure you have already removed the adjusting spanners.
- Before disconnecting compressed air hose from the tool make sure that there is no pressure in the hose.
- These instructions must be carefully followed.

WARNING!!! ALL OPERATIONS MUST BE DONE IN CONFORMITY WITH THE SAFETY REQUIREMENTS TO AVOID INJURY.

GENERAL NOTES AND USE

The tool can be employed only for threaded inserts with thread of M3 to M8 (metric tool) or #6-32 to 5/16-18 (unified tool) diameter. The AE 60 oil pneumatic system assures more power than the pneumatic system used for other models. That means a reduction in the problems due to the wear and tear of the components, therefore, there will be an increase in reliability. The technical solutions adopted reduce the dimensions and the weight of the tool which, for these reasons, make it very handy. The possibilities of leakage from the oil-dynamic system, are eliminated by some sealed gaskets, which solve this problem.

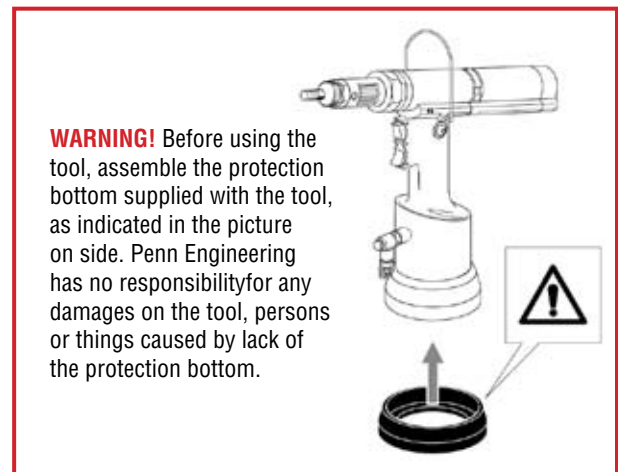

MAIN COMPONENTS



- A)..... Threaded tie rod
- B)..... Head
- C)..... Ring-nut clamping head
- D)..... Tensile strength pushbutton
- E)..... Unscrewing pushbutton
- F)..... Insertion Pin Hole Dechucking clutch
- G)..... Regulation stroke ring nut
- H)..... Balancer connection
- I)..... Motor
- L)..... Oil tank plug
- M)..... Compressed air connection
- N)..... Protection bottom

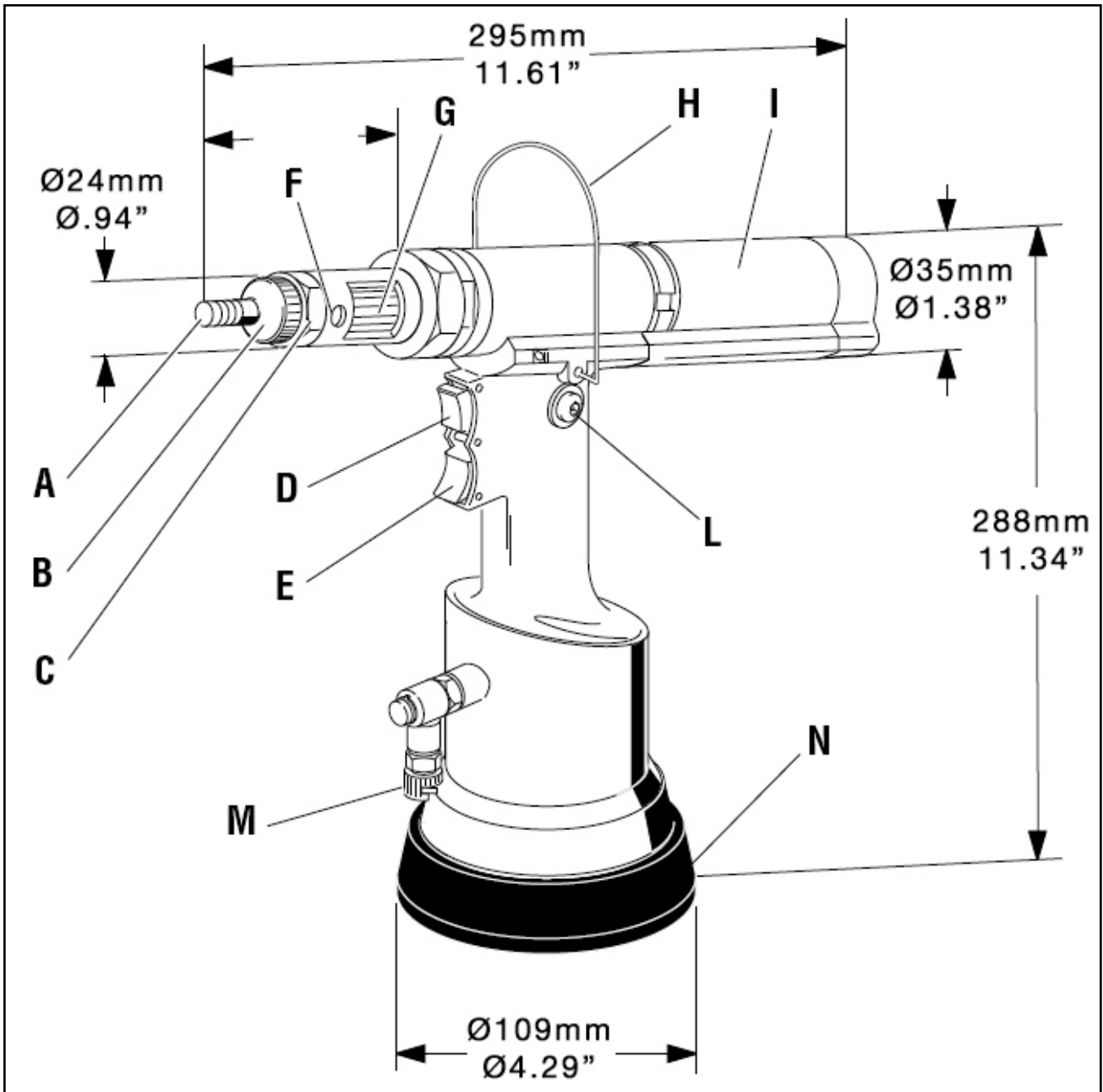

- Working pressure..... 6 BAR
- Min. int. diam. of the compressed air feeding hose.....min. diam = 8mm
- Air consumption per cycle..... 3.6 Lt.
- Max power..... 6 BAR -14224 N
- Weight..... 2.130 Kg
- Working temperature..... -5°/+50°C
- Root mean square in total acceleration frequency (Ac)
to which the arms are subjected..... < 2.5 m/sec²
- A-weighted emission sound pressure level..... 70 dBA
- Peak C-wdighted instantaneous sound pressure..... <130 dBC
- A-weighted emission sound pressure..... 88 dBA

AIR FEED

The air feed must be from foreign bodies and humidity in order to protect the tool from premature wear and tear of the components in movement, therefore we suggest to use a lubricative group for compressed air.

OPERATING INSTRUCTIONS



Make sure that the couple tie-rod/head mounted on your riveting tool is suitable for the insert to clamp; otherwise, change size accordingly. Usually the riveting tool is supplied with the couple tie-rod/head corresponding to a M8 thread. Before using the riveting tool and after any change of size, perform the following operations according to the size and thickness of the part to clamp. Adjust the riveting tool stroke to the minimum by turning the ring nut "G" to "-" marked on the tool. Place the insert onto the tie rod and push slightly on it so as to make it clamp automatically. Make sure the insert head touches the riveting tool head properly. Fasten the insert and in order to ensure a proper clamping of the material, adjust the riveting tool stroke by turning the ring nut "G" accordingly. By increasing stroke, i.e. by turning the ring nut "G" to "+", the distance "H" between head and insert deformation will decrease and clamping will result more effective.

WARNING!!! A WRONG ADJUSTMENT OF THE RIVETING TOOL STROKE MAY CAUSE A FAULTY CLAMPING OF INSERTS AND MAY BRAKE THE TIE ROD!

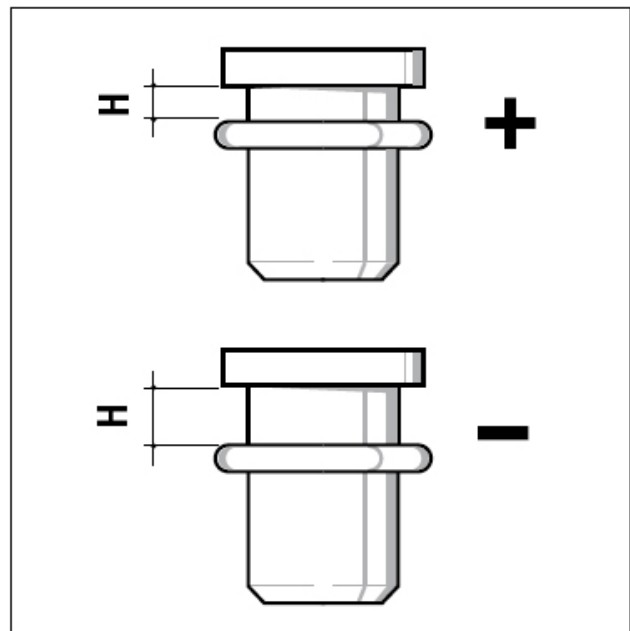
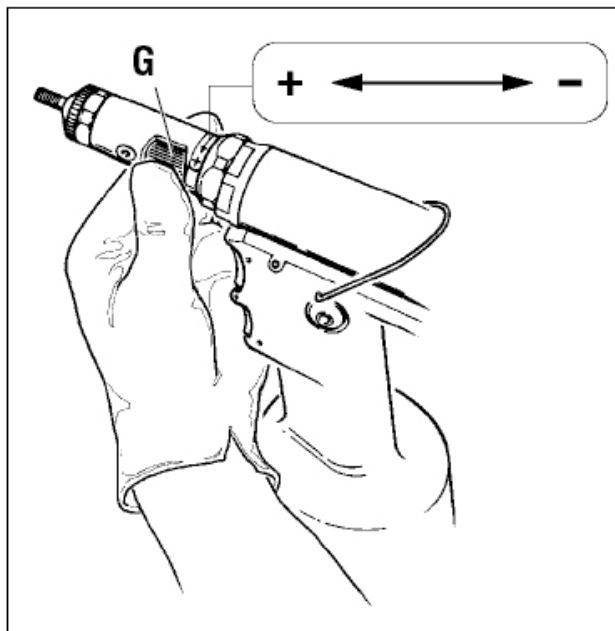
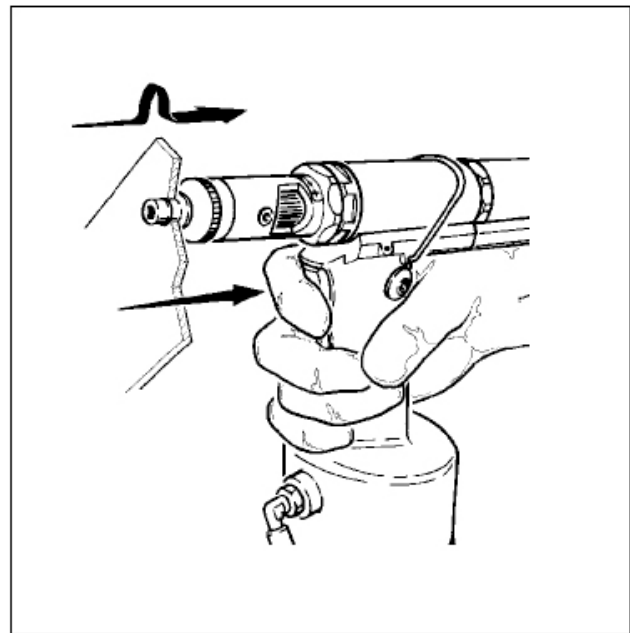
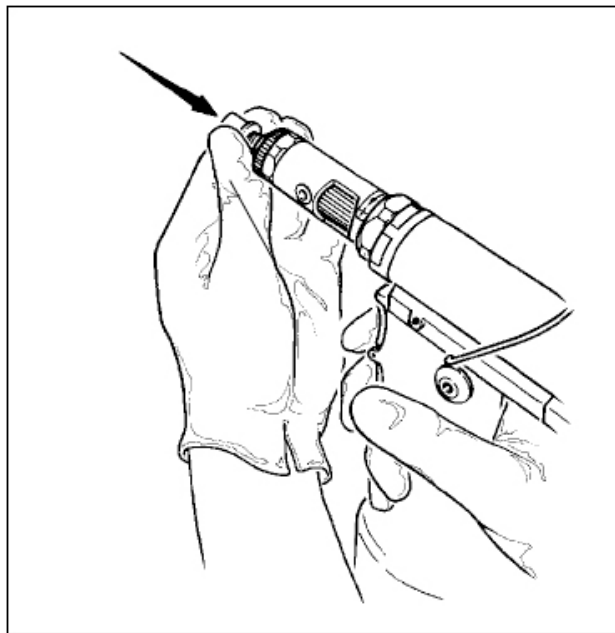

Depending on insert thread, it is necessary to replace the couple “tie-rod/head” as follows:

Picture 1. Loosen the ring nut by means of a 25-mm standard spanner and remove the riveting tool head.

Picture 2. Make the pin supplied pass through the pertinent service hole located on the cone carrying head and apply a light pressure on the head inwards, in order to dechuck the tie rod clutch, at the same time, unscrew the tie rod and extract it.

Picture 3-4. Keep the clutch dechucked and screw the tie rod size desired. When the replacement of the tie rod has been performed, swing it until you hear a click. The assemble the proper head and lock it with the corresponding ring nut loosen before. Each time you carry out and change of size, repeat the adjustment operations as specified in the previous pages.

WARNING! DISCONNECT AIR FEED WHEN PERFORMING THOSE OPERATIONS.

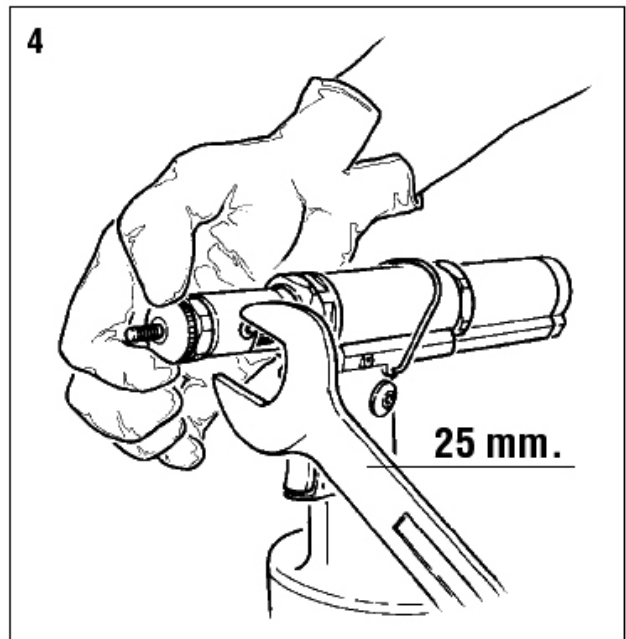
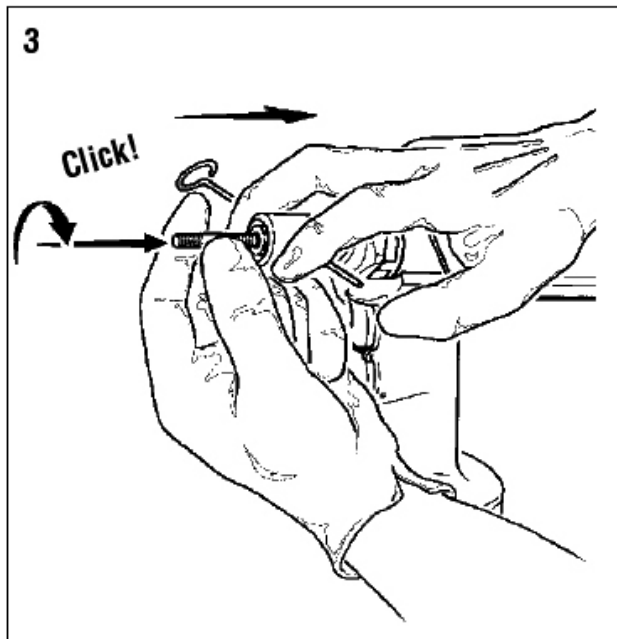
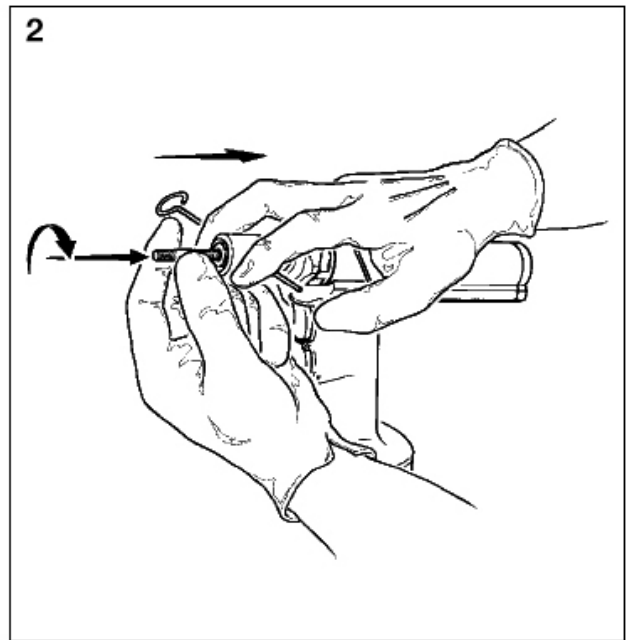
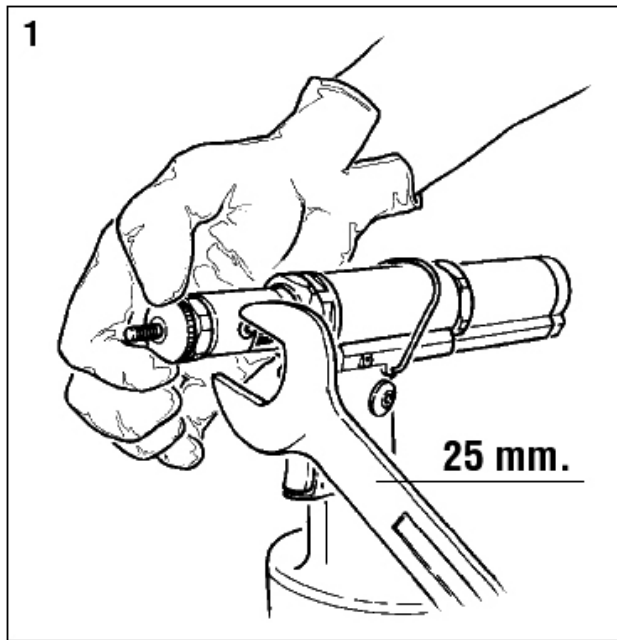

TOPPING UP THE OIL-DYNAMIC CIRCUIT



You need to top up the oil-dynamic circuit after a long period of work, when you note a power loss. Put the riveting tool (**DWELL AND NOT FED**) in a horizontal position and remove the plug (**A**), by means of a 5 mm Allen wrench (equipped with the riveting tool); during this operation, check the oil level in order to avoid any overflowing. Then, slowly pour the oil **PANOLIN HLP ISO 32** into the bellows container (**X**) which shall be screwed to its seat on the plug (**A**). While keeping the riveting tool in a horizontal position and **starting air feeding**, push the tensile strength button and make the riveting tool carry out some cycles until air bubbles inside the container (**X**) stop coming out. This condition indicates that the topping off the oil has fully been achieved. At this point **stop the air feeding** and, while keeping the riveting tool in a horizontal position, unscrew and close up the container (**X**) and the plug (**A**).

WARNING! Before disconnecting the compressed air hose, make sure that it is not under pressure! We recommend to use oil **PANOLIN HLP ISO 32 DIN 51524-2/HLP** or similar.

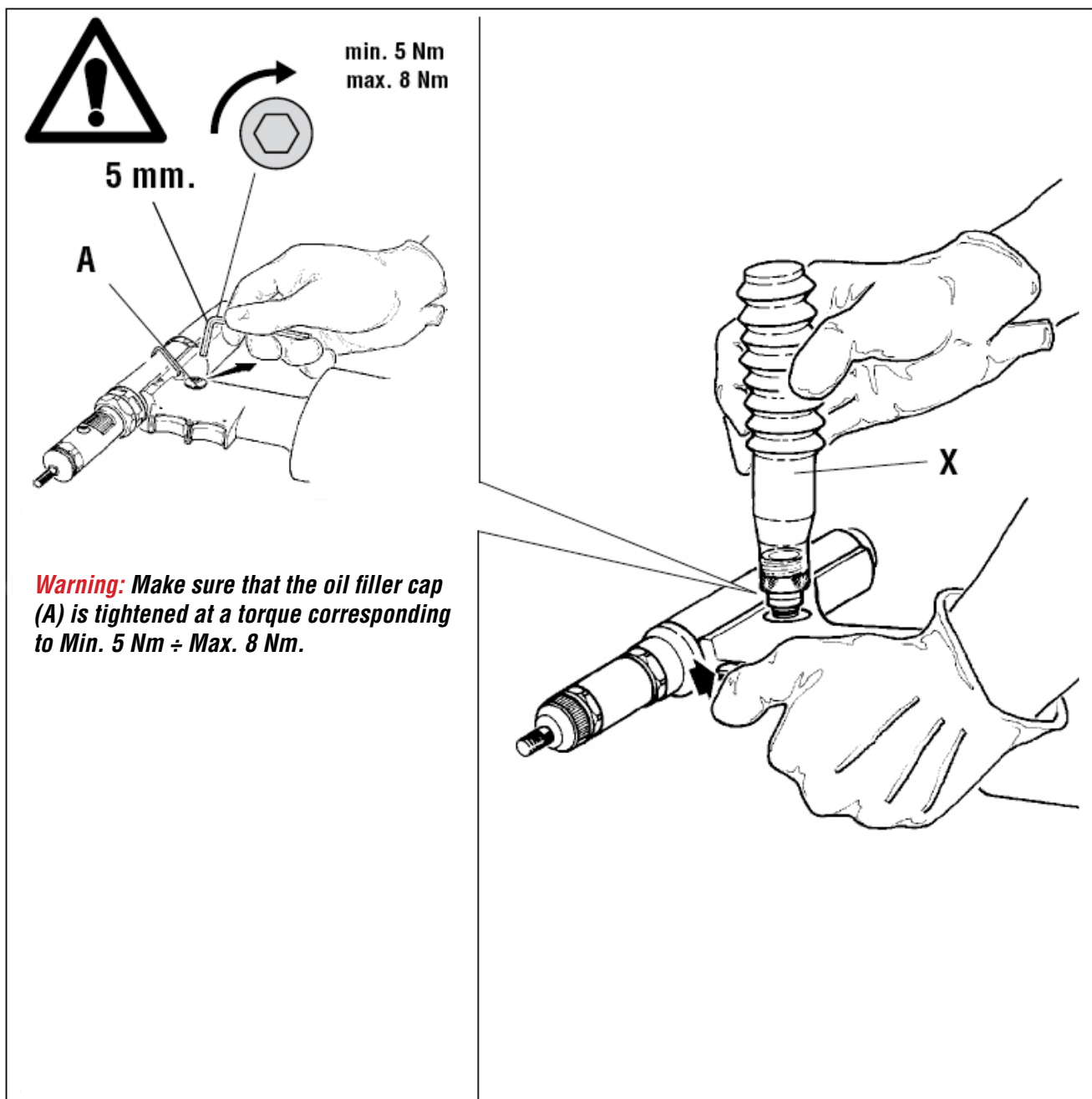

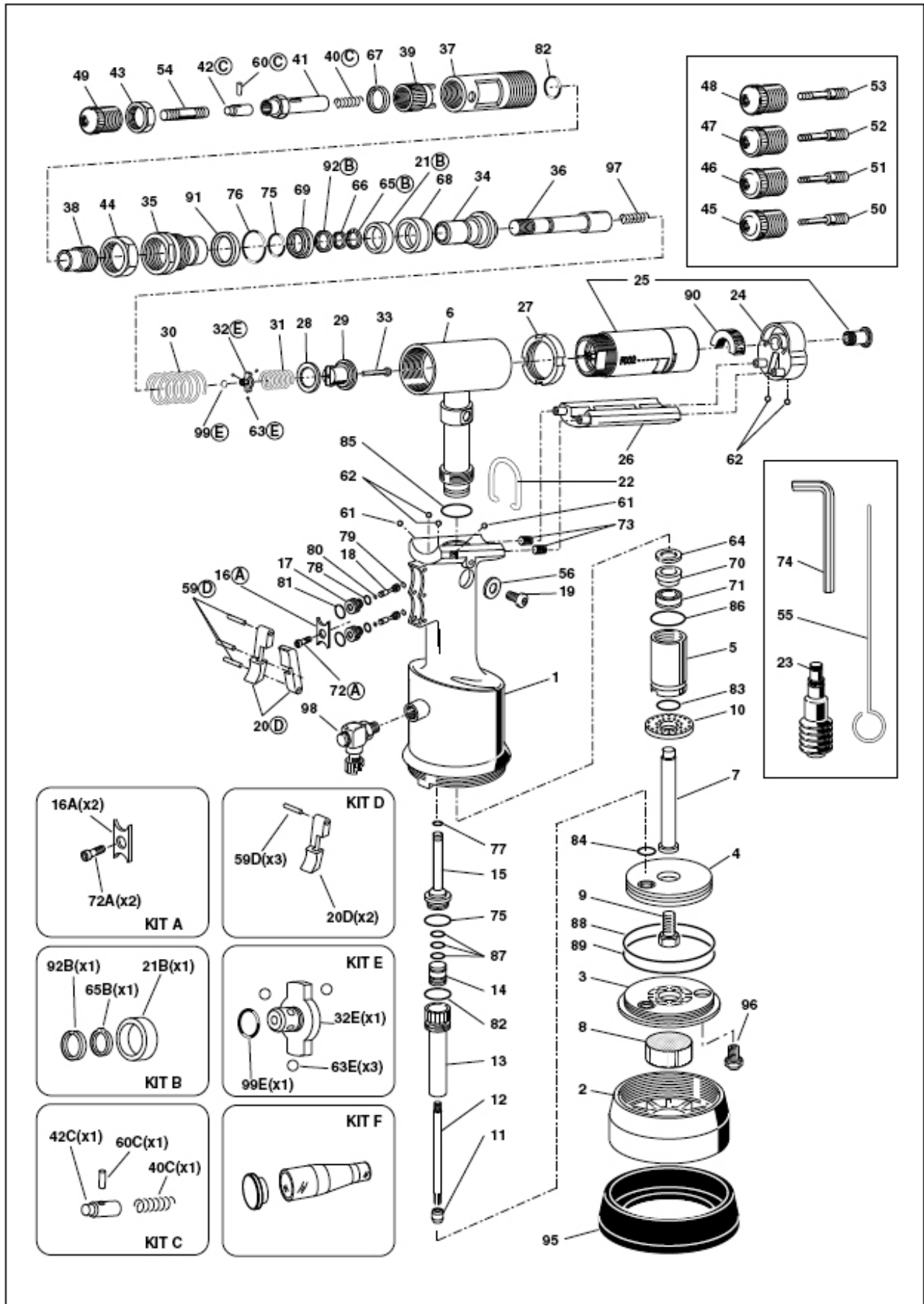

SPARE PARTS - METRIC TOOL



NO.	CODE	QTY.	DESCRIPTION
01	721779	1	Tool body
02	712269	1	Body cover
03	711684	1	Cylinder bottom
04	721685	1	Pneumatic piston
05	711780	1	Connector
06	721689	1	Oleodynamic cylinder
07	711781	1	Stem
08	711691	1	Silencer
09	711692	1	Screw M7x1
10	711782	1	Dampener
11	711694	1	Lower coil
12	711695	1	Threaded sleeve
13	721698	1	Valve body
14	711700	1	Upper coil
15	711701	1	Upper valve body
16A	711702	1	Plate
17	711703	2	Valve body
18	711704	2	Valve piston
19	710839	1	Oil tank plug
20D	711705	2	Push-button
21B	711713	1	Spacer
22	710854	1	Balancer hook
23	721387	1	Oil container
24	711783	1	Motor cover
25	720024	1	Motor F002
26	711785	1	Motor protection sector
27	711786	1	Ring nut for motor
28	711787	1	Stop ring
29	712670	1	Clutch
30	711790	1	Piston return spring
31	711791	1	Ball locking spring
32E	711792	1	Ball bushing
33	712270	1	Rod
34	711794	1	Oleodynamic Piston
35	711795	1	Front connector
36	711796	1	Shaft
37	711797	1	Milled sleeve
38	711798	1	Stroke adjusting nut
39	711799	1	Stroke adjusting knob
40C	711800	1	Spring disengagement tie rod
41	711801	1	Head carrying tie rod
42C	711802	1	Clutch for tie rod
43	711803	1	Head ring nut
44	711804	1	Ring nut
45	711805	1	Head M3
46	711806	1	Head M4
47	711807	1	Head M5
48	711808	1	Head M6
49	711809	1	Head M8
50	711810	1	Tie rod M3
51	711811	1	Tie rod M4
52	711812	1	Tie rod M5
53	711813	1	Tie rod M6
54	711814	1	Tie rod M8
55	710876	1	Pin disengagement tie rod
56	710906	1	Hermetic washer 400-820
59D	711726	3	Pin 2x20 UNI 1707
60C	710537	1	Spring pin 4x12
61	711815	2	Ball ø 3.5
62	710911	4	Ball ø 4
63E	711816	3	Ball ø 2.5
64	711817	1	Seeger ring I18
65B	710902	1	Seeger ring E16
66	711818	1	Seeger ring SW 11x1
67	711821	1	Seeger ring JV 20x1
68	711721	1	Balsele B-110078/B/NEO
69	711722	1	Balsele B-094063/B/NEI
70	711819	1	Balsele B-070039/1
71	711820	1	Gasket TS-10-18-5.8/L
72A	711727	1	Screw VSP-4x8 UNI 5933
73	712037	2	Inox filter ø 6x4
74	711092	1	Key mm5
75	711728	2	O Ring -2-16 P
76	711730	1	O Ring -2-119 (N552/90) P
77	710367	1	O Ring -2-8 P

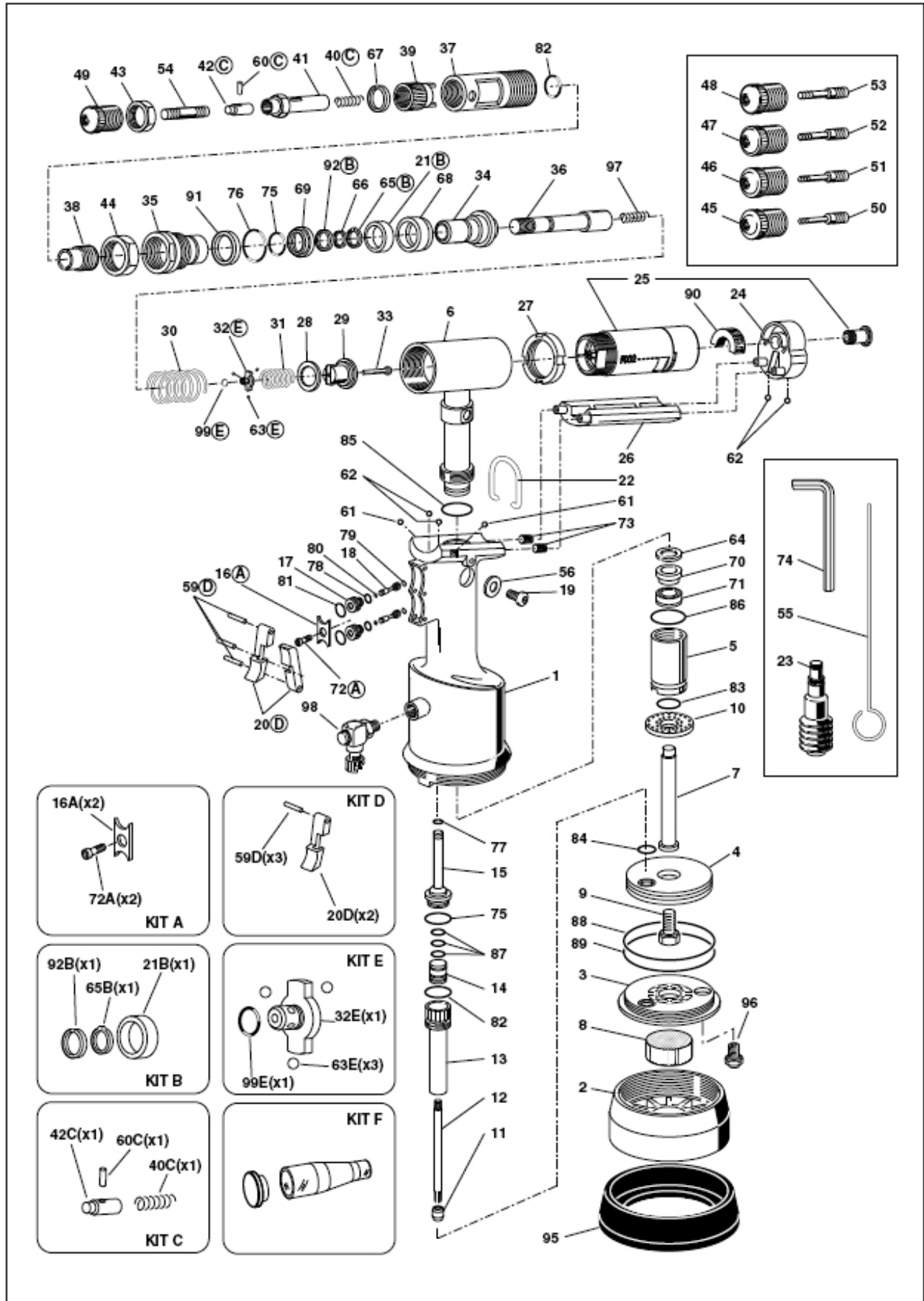

NO.	CODE	QTY.	DESCRIPTION
78	710376	2	O ring -2-9 P
79	710918	2	O ring -2-5 P
80	710919	2	O ring -2-4 P
81	710003	2	O ring -5-052 P
82	710342	2	O ring -2-17 P
83	710594	1	O ring -2-12 P
84	711061	1	O ring -5-614 P
85	711731	1	O ring -2-18 (N552/90) P
86	711732	1	O ring -2-118 P
87	710258	3	O ring -5-612 P
88	711734	1	O ring -2-232 P
89	711735	1	O ring -2-40 P
90	711834	1	Silencer
91	711917	1	Parbak 8.119
92B	711933	1	Seeger ring JV24
95	712159	1	Protection bottom
96	722047	1	Safety valve assembly
97	712153	1	Rod locking spring
98	712132	1	Rotating connector
99E	713341	1	O Ring 1x4

KIT			
NO.	CODE	QTY.	DESCRIPTION
KIT A	741702		Plate Kit
16A	711702	2	Plate
72A	711727	2	Screw VSP-4x8 UNI 5933
KIT B	741713		Spacer Kit
21B	711713	1	Spacer
65B	710902	1	Seeger ring E16
92B	711933	1	Seeger ring JV24
Kit C	741802		Clutch for tie rod kit
40C	711800	1	Spring disengagement tie rod
42C	711802	1	Clutch for tie rod
60C	710537	1	Spring pin 4x12
KIT D	741705		Push-button Kit
20D	711705	2	Push-button
59D	711726	3	Pin 2x20 UNI 1707
KIT E	741792		Ball bushing Kit
32E	711792	1	Ball bushing
63E	711816	3	Ball ø 2.5
99E	713341	1	O Ring 1x4
KIT F	7400043	1	Tie rod container kit
KIT	It indicates that the part is sold in kits consisting of different parts in different quantities.		

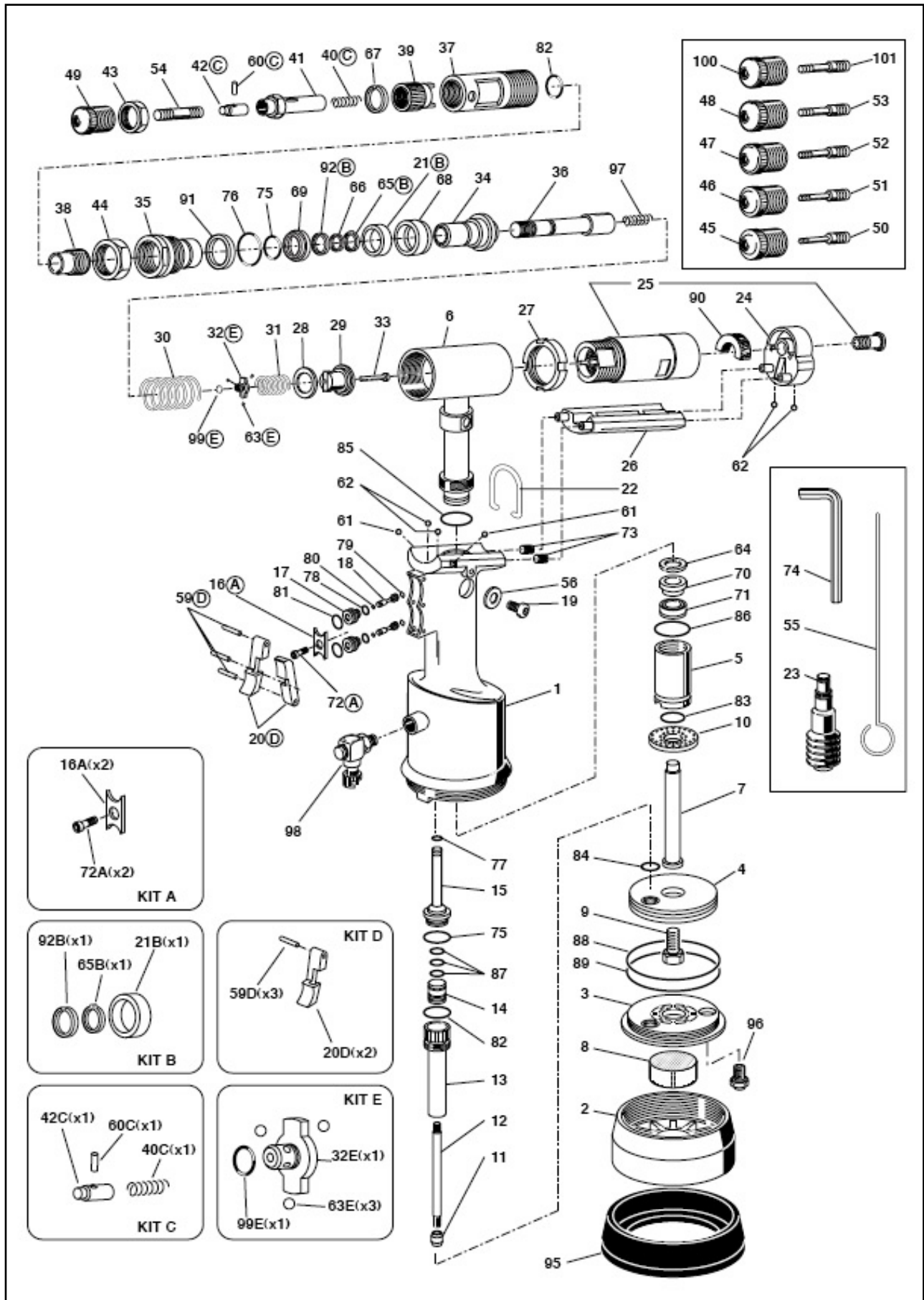

NO.	CODE	QTY.	DESCRIPTION
01	721779	1	Tool body
02	712269	1	Body cover
03	711684	1	Cylinder bottom
04	721685	1	Pneumatic piston
05	711780	1	Connector
06	721689	1	Oleodynamic cylinder
07	711781	1	Stem
08	711691	1	Silencer
09	711692	1	Screw M7x1
10	711782	1	Dampener
11	711694	1	Lower coil
12	711695	1	Threaded sleeve
13	721698	1	Valve body
14	711700	1	Upper coil
15	711701	1	Upper valve body
16A	711702	1	Plate
17	711703	2	Valve body
18	711704	2	Valve piston
19	710839	1	Oil tank plug
20D	711705	2	Push-button
21B	711713	1	Spacer
22	710854	1	Balancer hook
23	721387	1	Oil container
24	711783	1	Motor cover
25	720024	1	Motor AM-0001H
26	711785	1	Motor protection sector
27	711786	1	Ring nut for motor
28	711787	1	Stop ring
29	712670	1	Clutch
30	711790	1	Piston return spring
31	711791	1	Ball locking spring
32E	711792	1	Ball bushing
33	712270	1	Rod
34	711794	1	Oleodynamic Piston
35	711795	1	Front connector
36	711796	1	Shaft
37	711797	1	Milled sleeve
38	711798	1	Stroke adjusting nut
39	711799	1	Stroke adjusting knob
40C	711800	1	Spring disengagement tie rod
41	711801	1	Head carrying tie rod
42C	711802	1	Clutch for tie rod
43	711803	1	Head ring nut
44	711804	1	Ring nut
45	711884	1	Head 5/16-18
46	711885	1	Head 1/4-20
47	711886	1	Head 10-24 10-32
49	711887	1	Head 6-32
50	711878	1	Tie rod 5/16-18
51	711879	1	Tie rod 1/4-20
52	711880	1	Tie rod 10-24
53	711881	1	Tie rod 10-32
54	711882	1	Tie rod 6-32
55	710876	1	Pin disengagement tie rod
56	710906	1	Hermetic washer 400-820
59D	711726	3	Pin 2x20 UNI 1707
60C	710537	1	Spring pin 4x12
61	711815	2	Ball ø 3.5
62	710911	4	Ball ø 4
63E	711816	3	Ball ø 2.5
64	711817	1	Seeger ring I18
65B	710902	1	Seeger ring E16
66	711818	1	Seeger ring SW 11x1
67	711821	1	Seeger ring JV 20x1
68	711721	1	Balsele B-110078/B/NEO
69	711722	1	Balsele B-094063/B/NEI
70	711819	1	Balsele B-070039/1
71	711820	1	Gasket TS-10-18-5.8/L
72A	711727	1	Screw VSP-4x8 UNI 5933
73	712037	2	Inox filter ø 6x4
74	711092	1	Key 5mm
75	711728	2	O Ring -2-16 P
76	711730	1	O Ring -2-119 (N552/90) P
77	710367	1	O Ring -2-8 P

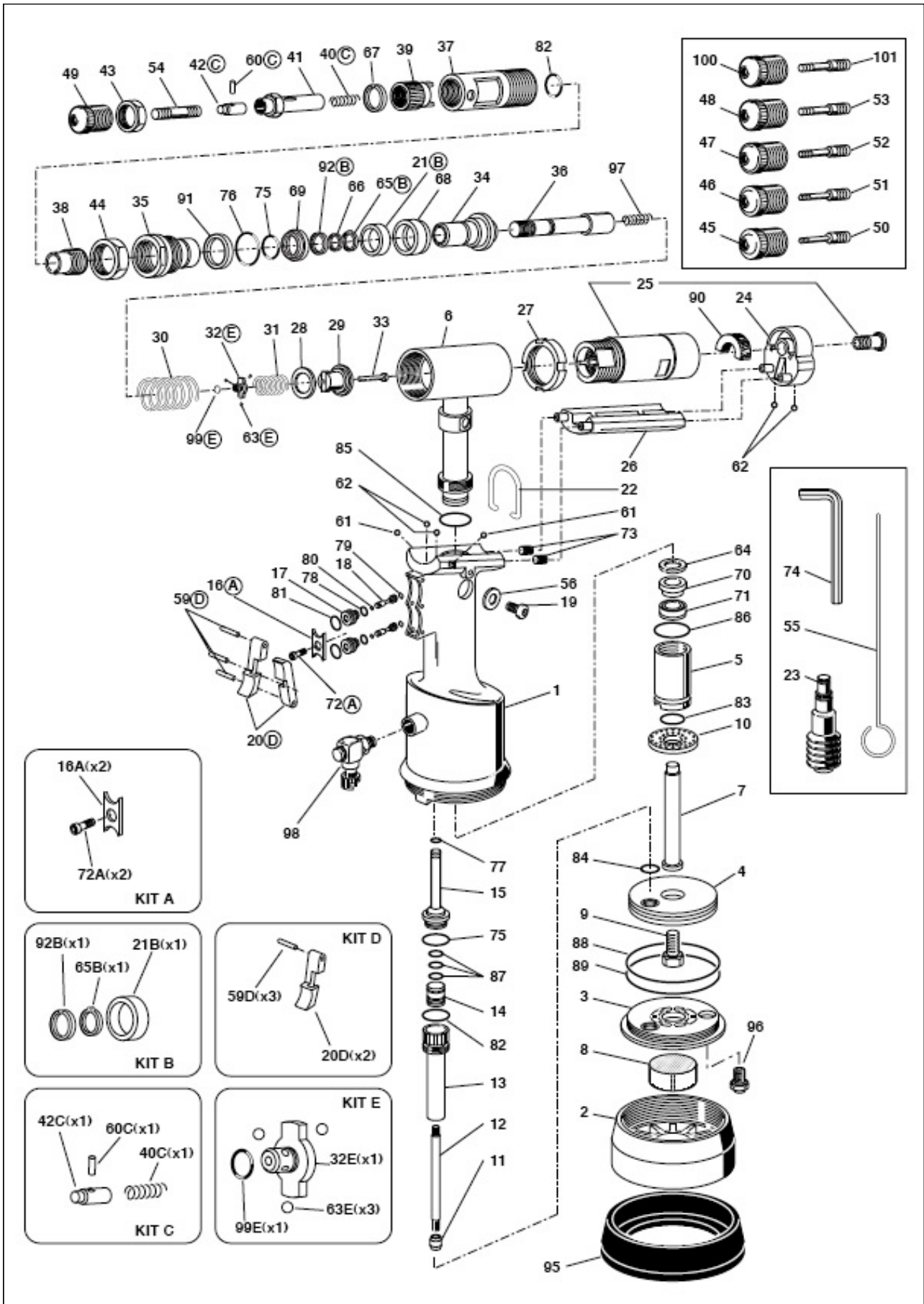

NO.	CODE	QTY.	DESCRIPTION
78	710376	2	O ring -2-9 P
79	710918	2	O ring -2-5 P
80	710919	2	O ring -2-4 P
81	710003	2	O ring -5-052 P
82	710342	2	O ring -2-17 P
83	710594	1	O ring -2-12 P
84	711061	1	O ring -5-614 P
85	711731	1	O ring -2-18 (N552/90) P
86	711732	1	O ring -2-118 P
87	710258	3	O ring -5-612 P
88	711734	1	O ring -2-232 P
89	711735	1	O ring -2-40 P
90	711834	1	Silencer
91	711917	1	Parbak 8.119
92B	711933	1	Seeger ring JV24
95	712159	1	Protection bottom
96	722047	1	Safety valve assembly
97	712153	1	Rod locking spring
98	712132	1	Rotating connector
99E	713341	1	O Ring 1x4
100	711888	1	Head 8-32
101	711883	1	Tie Rod 8-32

KIT			
NO.	CODE	QTY.	DESCRIPTION
KIT A	741702		Plate Kit
16A	711702	2	Plate
72A	711727	2	Screw VSP-4x8 UNI 5933
KIT B	741713		Spacer Kit
21B	711713	1	Spacer
65B	710902	1	Seeger ring E16
92B	711933	1	Seeger ring JV24
Kit C	741802		Clutch for tie rod kit
40C	711800	1	Spring disengagement tie rod
42C	711802	1	Clutch for tie rod
60C	710537	1	Spring pin 4x12
KIT D	741705		Push-button Kit
20D	711705	2	Push-button
59D	711726	3	Pin 2x20 UNI 1707
KIT E	741792		Ball bushing Kit
32E	711792	1	Ball bushing
63E	711816	3	Ball ø 2.5
99E	713341	1	O Ring 1x4
KIT	It indicates that the part is sold in kits consisting of different parts in different quantities.		

NO.	CODE	QTY.	DESCRIPTION
1	71345169	1	Connector
2	71C00764	1	Bearing 61801
3	71345646	1	Gear cage
4	71345644	3	Planetary gear
5	71345643	1	Crown gear
6	71345642	1	Washer
7	71C00763	1	Bearing AY7 ZZ C2
8	71345640	1	Connector
9	71C00761	2	Spring pin
10	71345639	5	Tongue
11	71345638	1	Rotor
12	71345637	1	Outside body
13	71345641	1	Back cap
14	71C00794	1	Pin $\varnothing 2 \times 7.8$
15	71C00762	1	Bearing 695-ZZ
16	710376	2	Gasket OR 2-009 Parker
17	71C00529	1	Gasket XR 008 PP180 B
18	720025	1	Motor driving rod
19	711869	1	Spring
20	711865	1	Screw M10
A	72A00126	1	Complete motor

KIT

NO.	CODE	QTY.	DESCRIPTION
KIT A	74000051		Body cover kit
KIT	It indicates that the part is sold in kits consisting of different parts in different quantities.		

