

PennEngineering®

SNAP-TOP® STANDOFFS



BULLETIN

SSA



610
REV 112

SNAP-TOP® STANDOFFS

PEM SNAP-TOP® Standoffs (Types SSA, SSS, SSC, KSSB) are designed for permanent installation into metal panels or PC boards.

These all-metal standoffs use a spring action to hold PC boards and subassemblies securely, while allowing for quick removal. Screws and other threaded hardware are eliminated. This means less parts to handle during assembly and less risk of damaging delicate circuitry because of loose parts falling into your equipment.

These standoffs are permanently installed in the panel by squeezing them into a properly sized hole using any standard press. Installation forces, pushout, and snap forces, are listed on page 6.

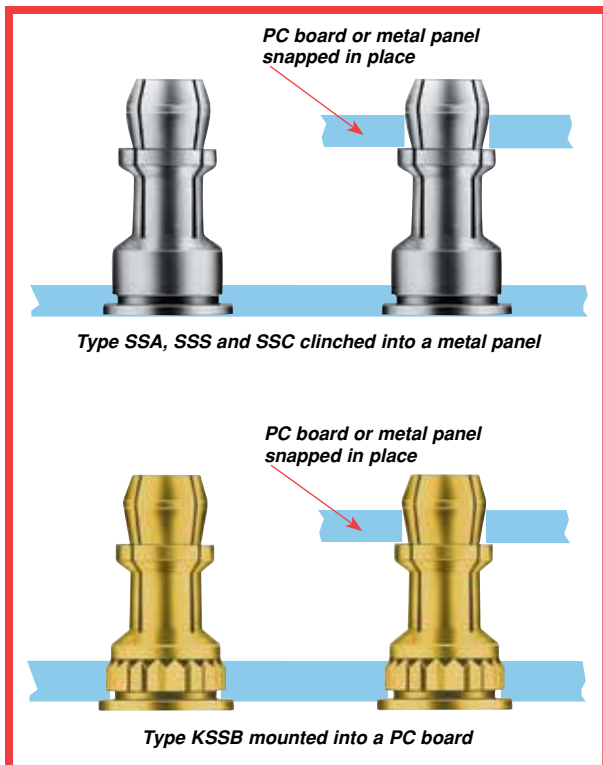

SNAP-TOP® STANDOFFS

TYPES SSA™ SSS™, AND SSC™ FOR CLINCHING INTO METAL SHEETS

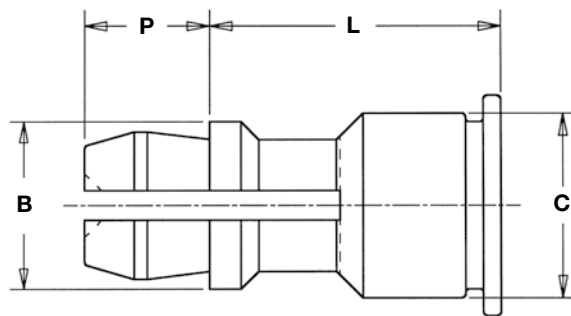
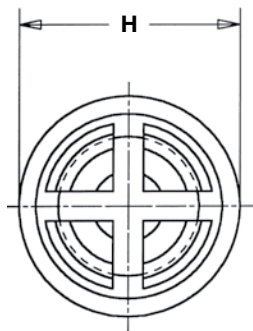

PART NUMBER DESIGNATION

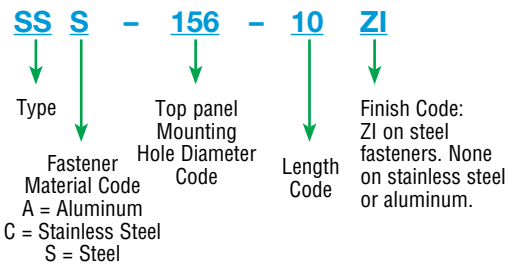

FASTENER MATERIAL:

- Type SSA– Aluminum
- Type SSS– Carbon Steel
- Type SSC– 400 Series Stainless Steel

FINISH:

- Type SSA– Plain Finish
- Type SSS– Zinc plated, 5µm, colorless, plus clear chromate (1)
- Type SSC– Passivated and/or tested per ASTM A380

DIMENSIONAL DATA

All dimensions are in inches.

UNIFIED	Type			Top Panel Mounting Hole Diameter Code	Length Code "L" ±.005 (Length Code in 32nds of an inch)										B ±.005	C Max.	H ±.005	P ±.005
	Fastener Material																	
	Aluminum	Carbon Steel	Stainless Steel															
SSA	SSS	SSC	156	.250	.312	.375	.437	.500	.562	.625	.750	.875	1.00	.188	.212	.250	.141	
				8	10	12	14	16	18	20	24	28	32					

All dimensions are in millimeters.

METRIC	Type			Top Panel Mounting Hole Diameter Code	Length Code "L" ±0.13 (Length Code in millimeters)										B ±0.13	C Max.	H ±0.13	P ±0.13
	Fastener Material																	
	Aluminum	Carbon Steel	Stainless Steel															
SSA	SSS	SSC	4mm	8	10	12	14	16	18	20	22	25	4.78	5.39	6.35	3.58		

(1) See PEM Technical Support section of our web site for related plating standards and specifications.

SNAP-TOP® STANDOFFS

TYPE KSSB™ FOR BROACHING INTO PC BOARDS

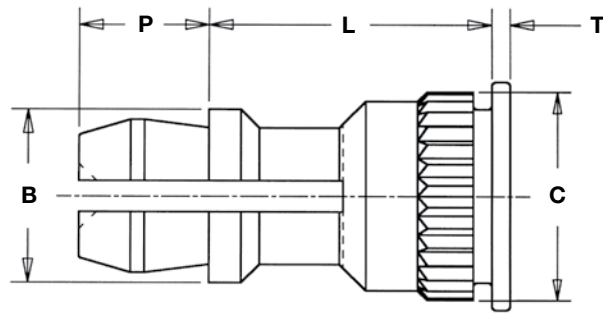
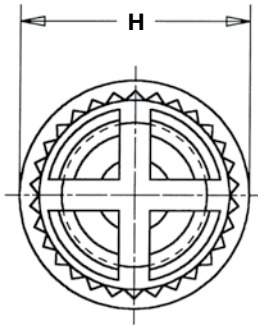

PART NUMBER DESIGNATION

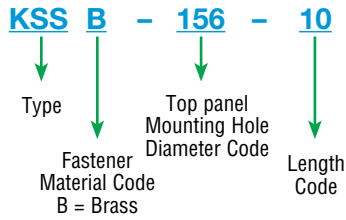

FASTENER MATERIAL:

Free Machining Brass

FINISH:

Standard – No Finish

Optional* – Electroplated Bright Tin,
ASTM B545 Class B (5µm)
with preservative coating

**Available on special order with additional charge.*

DIMENSIONAL DATA

All dimensions are in inches.

UNIFIED	Type	Top Panel Mounting Hole Diameter Code	Length Code "L" ±.005 (Length Code in 32nds of an inch)										B ±.005	C ±.003	H ±.005	P ±.005	T ±.005
	KSSB	156		.250	.312	.375	.437	.500	.562	.625	.750	.875	1.00	.188	.226	.250	.141
			8	10	12	14	16	18	20	24	28	32					

All dimensions are in millimeters.

METRIC	Type	Top Panel Mounting Hole Diameter Code	Length Code "L" ±0.13 (Length Code in millimeters)										B ±0.13	C ±0.08	H ±0.13	P ±0.13	T ±0.13
	KSSB	4mm		8	10	12	14	16	18	20	22	25	4.78	5.74	6.35	3.58	0.51



SNAP-TOP® STANDOFFS

APPLICATION DATA TYPES SSA, SSS, SSC

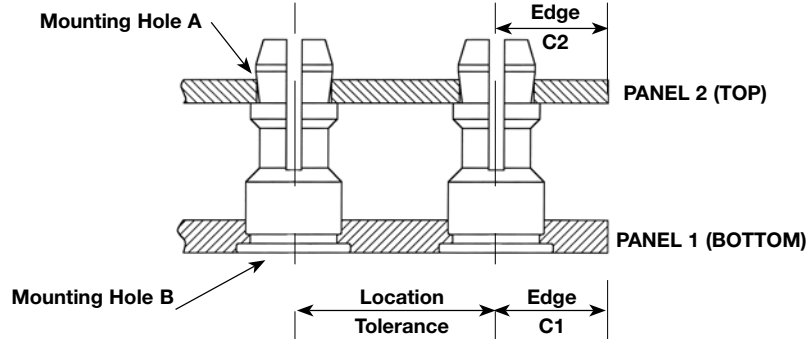

All dimensions are in inches.

UNIFIED	Panel 1							Panel 2				
	Type	Hardness Max. (1)	Bottom Mounting Hole B +.003 -.000	Panel Material	Thickness Min.	Edge Distance C ₁ Min.	Location Tolerance Max.	Hardness Max.	Top Mounting Hole A +.003 -.000	Panel Material	Thickness Range (2)	Edge Distance C ₂ Min.
	SSA	HRB 50 / HB 82	.213	Metal ⁽¹⁾	.040	.260	±.005	No Limit	.156	PC Board or Metal	.040 - .070	.100
	SSS	HRB 60 / HB 107										
	SSC	HRB 70 / HB 125										

All dimensions are in millimeters.

METRIC	Panel 1							Panel 2				
	Type	Hardness Max. (1)	Bottom Mounting Hole B +0.08	Panel Material	Thickness Min.	Edge Distance C ₁ Min.	Location Tolerance Max.	Hardness Max.	Top Mounting Hole A +0.08	Panel Material	Thickness Range (2)	Edge Distance C ₂ Min.
	SSA	HRB 50 / HB 82	5.41	Metal ⁽¹⁾	1	6.6	±0.134	No Limit	4	PC Board or Metal	1 - 1.8	2.54
	SSS	HRB 60 / HB 107										
	SSC	HRB 70 / HB 125										

(1) Type SSA standoffs can be installed into cold-rolled steel provided hardness is less than HRB 50. HRB - Hardness Rockwell "B" Scale. HB - Hardness Brinell.

APPLICATION DATA TYPE KSSB

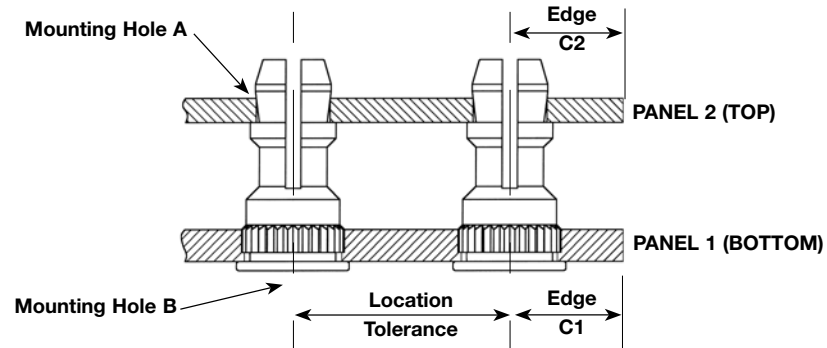

All dimensions are in inches.

UNIFIED	Panel 1							Panel 2				
	Type	Hardness Max. (2)	Bottom Mounting Hole B +.003 -.000	Panel Material	Thickness Min.	Edge Distance C ₁ Min.	Location Tolerance Max.	Hardness Max. (2)	Top Mounting Hole A +.003 -.000	Panel Material	Thickness Range (3)	Edge Distance C ₂ Min.
	KSSB	HRB 65 / HB 116	.213	PC Board	.050	.220	±.005	No Limit	.156	PC Board or Metal	.040 - .070	.100

All dimensions are in millimeters.

METRIC	Panel 1							Panel 2				
	Type	Hardness Max. (2)	Bottom Mounting Hole B +0.08	Panel Material	Thickness Min.	Edge Distance C ₁ Min.	Location Tolerance Max.	Hardness Max. (2)	Top Mounting Hole A +0.08	Panel Material	Thickness Range (3)	Edge Distance C ₂ Min.
	KSSB	HRB 65 / HB 116	5.41	PC Board	1.27	5.59	±0.13	No Limit	4	PC Board or Metal	1 - 1.8	2.54

(2) HRB - Hardness Rockwell "B" Scale. HB - Hardness Brinell.

(3) Available for thicker boards on special order.

SNAP-TOP® STANDOFFS

INSTALLATION

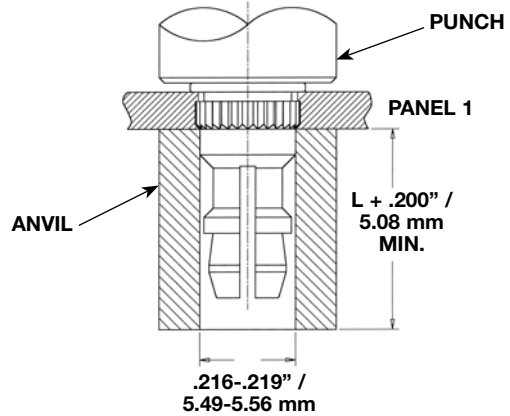
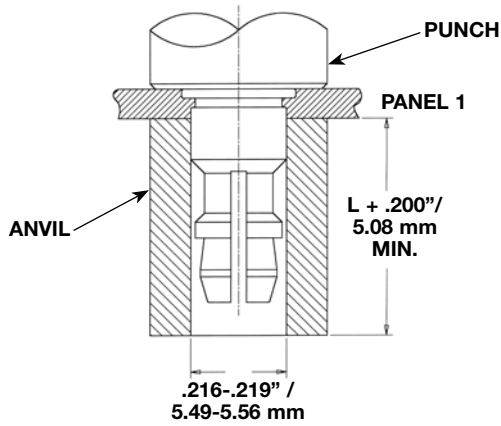

Types SSA, SSS, SSC

1. Prepare properly sized mounting hole in the panel.
2. Place the fastener through the mounting hole (preferably the punch side) of the panel and into the anvil as shown in the drawing.
3. With punch and anvil surfaces parallel, apply only enough squeezing force to embed the head flush with the panel.

Type KSSB

1. Prepare properly sized mounting hole in the board.
2. Place the fastener through the mounting hole of the board and into the anvil as shown in the drawing.
3. With punch and anvil surfaces parallel, apply only enough squeezing force to bring the head into contact with the board.

PERFORMANCE DATA⁽¹⁾

UNIFIED	Type	Panel 1			Panel 2 (Removable)		
		Test Sheet Material	Installation (lbs.)	Pushout (lbs.)	Max. First on Snap Force (lbs.)	Min. First off Snap Force (lbs.)	Min. 15th off Snap Force (lbs.)
	SSA	Aluminum	1500	200	13	3	1
	SSS	Aluminum	1500	200	20	6	2
	SSS	Cold-rolled Steel	3500	400	20	6	2
	SSC	Cold-rolled Steel	3600	400	20	6	2
	KSSB	FR-4 Fiberglass	500	110	13	3	1

METRIC	Type	Panel 1			Panel 2 (Removable)		
		Test Sheet Material	Installation (kN)	Pushout (N)	Max. First on Snap Force (N)	Min. First off Snap Force (N)	Min. 15th off Snap Force (N)
	SSA	Aluminum	6.7	880	58	13	4
	SSS	Aluminum	6.7	880	89	27	9
	SSS	Cold-rolled Steel	15.5	1780	89	27	9
	SSC	Cold-rolled Steel	16	1780	89	27	9
	KSSB	FR-4 Fiberglass	2.2	484	58	13	4

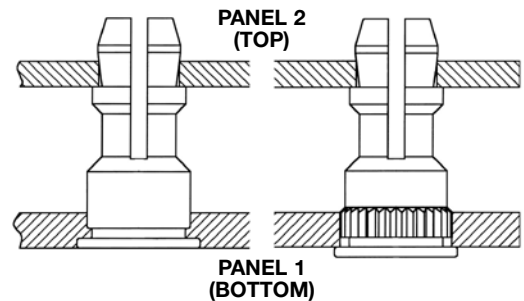

(1) The values reported are averages when all installation specifications and procedures are followed. Variations in mounting hole size, panel material and installation procedure will affect results. Performance testing of this product in your application is recommended. We will be happy to provide samples for this purpose.

RoHS compliance information can be found on our website.
© 2011 PennEngineering.

Specifications subject to change without notice.
See our website for the most current version of this bulletin.

PennEngineering®



North America: Danboro, PA USA • E-mail: info@pemnet.com • Tel: +1-215-766-8853 • Fax: +1-215-766-0143 • 800-237-4736 (USA Only)
Europe: Galway, Ireland • E-mail: europe@pemnet.com • Tel: +353-91-751714 • Fax: +353-91-753541
Asia/Pacific: Singapore • E-mail: singapore@pemnet.com • Tel: +65-6-745-0660 • Fax: +65-6-745-2400
 Shanghai, China • E-mail: china@pemnet.com • Tel: +86-21-5868-3688 • Fax: +86-21-5868-3988

Visit our PEMNET™ Resource Center at www.pemnet.com

Technical support e-mail: techsupport@pemnet.com